

HERCULES™

COMMERCIAL FRONT LOADER



Proven Technology With Years of Experience

- No Onboard Computers or PLC – Easy to Troubleshoot and Maintain
- Simple Controls Are Easy to Learn, Easy to Operate
- Simple and Efficient Hydraulic Routing Is Clean, Logical, Easy to Service and Maintain
- Hydraulics Feature Zinc Dichromate Plated Tubing, with Unpainted Hoses and Fittings
- Gladiator™ Pack/Eject Cylinder Is Industry's Most Advanced Scraper Cylinder • Gladiator™ Cylinders Include a 3-Year Warranty
- Powder Coat Paint Is Far Superior to Wet Paint – An E-Z Pack Exclusive
- Smart Steel Engineering Reduces Body Weight, Maximizes Payload
- 1-Year Full Body Warranty



Available with Patent Pending, Integrated CNG Fuel System



So Advanced, It's Simple



Refuse Hauling Solutions, LLC

Holtz Industries, Inc | 200 South Terrace Ct | Newark, OH 43055

TF: 1-800-535-0104 | Fax: 740-366-0771

E-Z Pack

HERCULES™ Commercial Front Loader SPECIFICATIONS

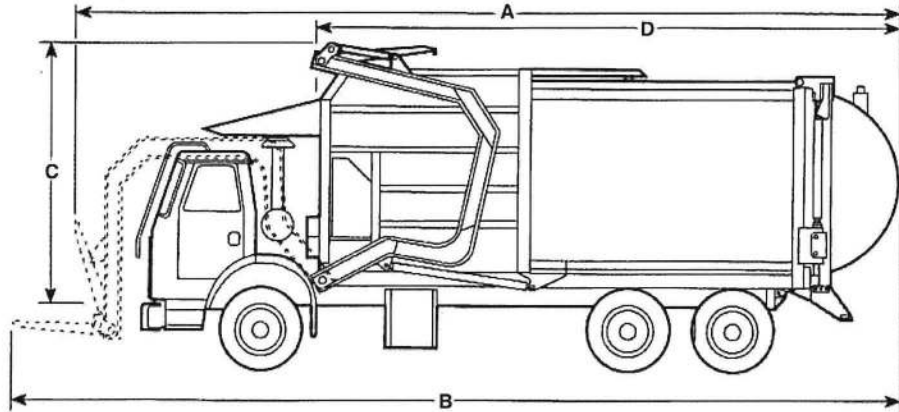

MODEL	35 Cu. Yd. (26.8 m ³)	37 Cu. Yd. (28.3 m ³)	40 Cu. Yd. (30.6 m ³)	44 Cu. Yd. (33.6 m ³)
A OVERALL LENGTH (Forks Perpendicular)	374.75" (9519 mm)	386.75" (9823 mm)	410.75" (10,433 mm)	422.75" (10,738 mm)
B OVERALL LENGTH (Forks Parallel)	413.25" (10,497 mm)	425.75" (10,814 mm)	449.75" (11,424 mm)	461.75" (11,728 mm)
C HEIGHT (Above Chassis Frame)	119.25" (3029 mm)			
D LENGTH (Body & Tailgate)	253" (6426 mm)	265" (6731 mm)	289" (7341 mm)	301" (7645 mm)
INSIDE WIDTH (Hopper)	80.25" (2038 mm)			
INSIDE WIDTH (Body)	88" (2235 mm)			
INSIDE HEIGHT (Body)	98" (2489 mm)			
INSIDE HEIGHT (Hopper)	93.25" (2369 mm)			
OVERALL WIDTH	96" (2438 mm)			
HOPPER WIDTH	80.25" (2038 mm)			
HOPPER LENGTH	89" (2261 mm)		101" (2565 mm)	
WEIGHT	17,400 lbs. (7893 kg)	17,600 lbs. (7983 kg)	18,200 lbs. (8256 kg)	18,400 lbs. (8346 kg)

CONSTRUCTION AND OPERATIONAL DETAILS	
Hopper Floor	1/4" Plate (6.35 mm) 155,000 PSI 400 BHN
Hopper Sides (Upper)	10 ga. (3.42 mm) 100,000 PSI
Hopper Sides (Lower)	7 ga. (4.55 mm) 100,000 PSI
Body Floor	7 ga. (4.55 mm) 100,000 PSI
Body Sides	10 ga. (3.42 mm) 100,000 PSI
Body Roof	10 ga. (3.42 mm) 100,000 PSI
Gate Bubble	10 ga. (3.42 mm) 100,000 PSI
HYDRAULIC SYSTEM	
Packing Cylinders (2) Full Eject (Gladiator™)	5-1/2" (140 mm) 118,792 lbs. Packing Force
Interlaced 10" (254 mm) Longitudinals Under 10 Cu. Yd. (7.6 m ³) Hopper	
Flange Type 13" (320 mm) Wide Longmembers Under body	
Lift Arm Cylinders (2) with Steel Rod Scrapers	4-1/2" (114 mm) (D.A.)
Fork Cylinders (2) with Steel Rod Scrapers	4" (102 mm) (D.A.)
Tailgate Cylinders (2)	3" (76 mm) (D.A.)
Hopper Door Cylinder	3" (76 mm) (D.A.)
Hydraulic Oil Tank	47 Gallons (178 Liters)
Hydraulic Pump	42 G.P.M. @ 1200 RPM (159 Liter/Min.)
Hydraulic Filters	6 Micron Return / 3 Micron Breathers
System Operating Pressure	2,500 PSI
<i>SPECIAL NOTE: Chassis equipped with diesel engine requires full variable speed governor</i>	

Standard Features

- 100 Gallon (380 Liters) sump created by curved rear body floor
- Full Eject, Gladiator™ Pack/Eject Cylinders
- Body floor, sides and roof radiused for greater strength
- 4 packing blade shoes (2 center mounted), replaceable without removing packing blade
- Automatic latch/unlatch tailgate
- 25 second packing cycle time, 20 second container dump time
- Automatic packing cycle
- Filtration 3 micron return with electric dirt indicator, in cab warning
- Leak-proof JIC hydraulic seals
- LED Lights
- High mount light package
- Air controls
- Sliding hopper cover
- Mounting bracket for strobe and camera
- Tailgate maintenance props
- 1-Year full body warranty

Optional Equipment

- West Coast lightweight body
- Residential package
- 10 gauge hopper side liners
- Shark's teeth load retainers
- 10,000 lb. lift arm capacity
- 60" extended forks
- Fork stop kit
- Installation of body or fork mount scale system
- Front body screen enclosure with valve cover
- 10" cabshield extension
- Front body sump doors or sump overlay
- Partial raise service hoist
- Remote lube fittings for packer panel
- Washout tank
- Camera systems
- Outside controls
- Container flood light
- Hopper flood light
- Strobe/rotating beacon lights
- Trapezoidal reverse side lights
- High pressure filter
- Spare filter package
- Plastic clean-out shovel

E-Z Pack Refuse Hauling Solutions, LLC, reserves the right under its Product Improvement Program to modify construction and/or design and furnish equipment without reference to illustrations and specifications shown herein. All specifications are subject to change without notice.



Authorized Distributor: