

# HERCULES™

## AUTOMATED SIDE LOADER



### *The First High Compaction Automated Side Loader*

- Proven Hercules High Compaction Body – Packs Up To 1,000 Lbs per Yd<sup>3</sup>
- Commonality of Components With Other Hercules Bodies in the Field Saves on Training, Service, and Maintenance Costs
- 6 Yd<sup>3</sup> Hopper is Largest Available
- Dependable, Proven Arm Design
- Simple Controls – No Onboard Computers or PLCs – Easy to Learn, Easy to Maintain
- Operate In Gear at Idle – Saves Fuel
- Gladiator™ Pack/Eject Cylinder Is Industry's Most Advanced Scraper Cylinder, and Includes a 3-Year Warranty
- Powder Coat Paint Is Far Superior to Wet Paint – an E-Z Pack Exclusive
- Smart Steel Engineering Reduces Body Weight, Maximizes Payload
- Optional CNG Tailgate Technology with Integrated Fuel Cells, Patent Pending

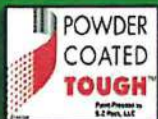

Scan This Code  
& See The Video



Available with Patent Pending,  
Integrated CNG Fuel System



*So Advanced, It's Simple*



Refuse Hauling Solutions, LLC

Holtz Industries, Inc. | 200 South Terrace Ct | Newark, OH 43055

TF: 1-800-535-0104 | Fax: 740-366-0771

# E-Z Pack

## HERCULES™

### Automated Side Loader

### SPECIFICATIONS

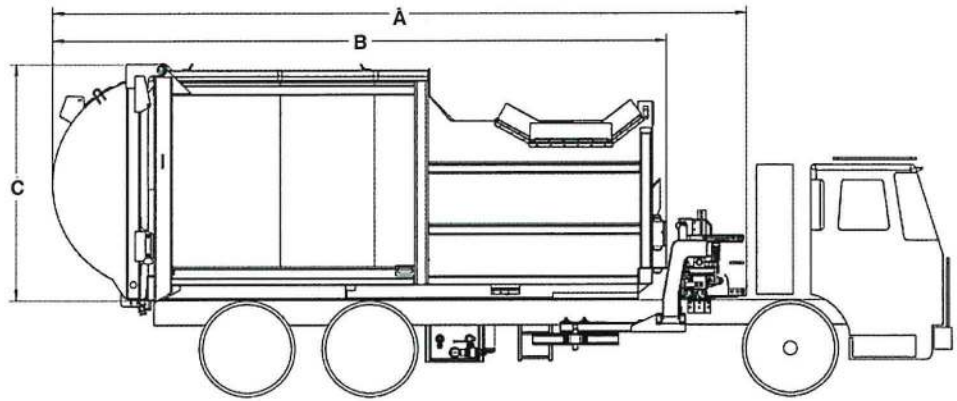

MODEL	23 Cu. Yd. (17.6 m <sup>3</sup> )	25 Cu. Yd. (19.1 m <sup>3</sup> )	27 Cu. Yd. (20.6 m <sup>3</sup> )	30 Cu. Yd. (22.9 m <sup>3</sup> )
<b>A</b> OVERALL LENGTH (Including Arm)	280" (7112 mm)	294" (7468 mm)	306" (7772 mm)	318" (8077 mm)
<b>B</b> OVERALL LENGTH (Body Only)	244" (6198 mm)	258" (6553 mm)	270" (6858 mm)	282" (7163 mm)
<b>C</b> HEIGHT Above Chassis Frame (Arm Down)	103" (2616 mm)			
HOPPER VOLUME	6 Cu. Yd. (4.6 m <sup>3</sup> )			
HOPPER OPENING WIDTH	80.25" (2038 mm)			
HOPPER OPENING LENGTH	60" (1524 mm)			
INSIDE WIDTH (Body)	88" (2235 mm)			
INSIDE HEIGHT (Body)	95" (2413 mm)			
OVERALL WIDTH	96" (2438 mm)			
WEIGHT	14,700 lbs. (6668 kg)	14,800 lbs. (6713 kg)	15,000 lbs. (6804 kg)	15,400 lbs. (6985 kg)
FRONT AXLE RATING (Min)	14,000 lbs. (6350 kg)	14,000 lbs. (6350 kg)	16,000 lbs. (7258 kg)	18,000 lbs. (8165 kg)
REAR AXLE RATING (Min)	33,000 lbs. (14,969 kg)	38,000 lbs. (17,237 kg)	44,000 lbs. (19,958 kg)	44,000 lbs. (19,958 kg)
<b>PERFORMANCE</b>				
ARM REACH (From Side of Body)	108" (2743 mm)			
ARM LIFTING CAPACITY	1500 lbs. (680kg)			
ARM CYCLE TIME	8-10 Seconds			
PACKING CYCLE TIME	20 Seconds			
EJECTION CYCLE TIME	35 Seconds			
TAILGATE OPEN / CLOSE	15 Sec. / 20 Sec.			

CONSTRUCTION AND OPERATIONAL DETAILS	
Hopper Floor (Material Area)	3/16" (4.76 mm) 155,000 PSI 400 BHN
Hopper Floor (Under Packer Blade)	10 ga. (3.42 mm) 100,000 PSI
Hopper Sides (Upper)	10 ga. (3.42 mm) 100,000 PSI
Hopper Sides (Lower)	7 ga. (4.55 mm) 100,000 PSI
Arm Wrapper Bars	3/4" (19.05 mm) 80,000 PSI
Arm Side Plates	1/4" (6.35 mm) 100,000 PSI
Body Floor	10 ga. (3.42 mm) 100,000 PSI
Body Sides	10 ga. (3.42 mm) 100,000 PSI
Body Roof	10 ga. (3.42 mm) 100,000 PSI
Tailgate Sides and Bubble	10 ga. (3.42 mm) 100,000 PSI
Interlaced 10" (254 mm) Longitudinals Under Hopper - Flange Type 13" (320 mm) Wide Longmembers Under Body	
CONTROLS	
Arm	Electric Over Hydraulic
Packer Blade	Electric Over Air
Tailgate	Electric Over Hydraulic
HYDRAULIC SYSTEM	
Type	Load Sense
System Operating Pressure	2650 PSI
Hydraulic Pump	Piston, Front Mount, Crankshaft Driven - 42 GPM @ 1200 RPM (159 Liter/Min.)
Hydraulic Flow Required for Performance Specs	12 GPM, Arm (45.42 Liter/Min.)
System Rate Flow Capacity	70 GPM (265 Liter/Min.)
Hydraulic Tank Capacity (Pressurized Tank)	47 Gallons (178 Liters)
Lift Arm Cylinder	3-1/2" (89 mm) (D.A.)
Reach Cylinder	1-7/8" (47.63 mm) (D.A.)
Tailgate Cylinders (2)	3" (76 mm) (D.A.)
Packing Cylinders (2) Full Eject, Gladiator™	5-1/2" (140 mm) 118,792 lbs. Packing Force
Hydraulic Filters	3 Micron Pressure / 3 Micron Return / 3 Micron Breathers
Grabbers	30-120 Gallon, Standard

### Standard Features

- Patented Load Sense Hydraulic System, saves fuel and improves performance
- 100 Gallon (380 Liters) sump created by curved rear body floor
- Body floor, sides and roof radiused for greater strength
- 4 packing blade shoes (2 center mounted), replaceable without removing packing blade
- Operate in gear at idle
- Simultaneous packing
- Coordinated lift arm controls
- Mounting bracket for strobe and camera
- Hopper side access door (interlocked)
- Auto dump cycle
- Continuous loading
- Automatic latch/unlatch tailgate
- Hopper side clean out hatch
- Tailgate maintenance props
- Automatic packing cycle
- Soft shift arm valve
- High mount light package
- Clean out tool

E-Z Pack Refuse Hauling Solutions, LLC, reserves the right under its Product Improvement Program to modify construction and/or design and furnish equipment without reference to illustrations and specifications shown herein. All specifications are subject to change without notice.



Authorized Distributor: