

EVTL Double-Wide Trunion Series



Features:

- Powered by the patented Thinline rack and pinion rotary actuator for smooth operation
- Compatible with both European style roll-out carts as well as 4-wheel comb lift and trunion lift containers
- Dumps cart higher and deeper inside the hopper opening to prevent spillage and increase route stops before cycling packer blade
- Self-lubricating composite bearings at main pivot points
- Powder-coated finish for durability

Specifications:

Cart Compatibility:	ANSI Z245.60-1996 Type C Carts (European Style), 660, 770, 1100 Liter 4-Wheel Comb Lift and Trunion Containers
Lift Capacity:	800 lbs @ 2300 psi
Hydraulic Pressures:	Working Pressure: 2300 psi Maximum Pressure: 2500 psi
Hydraulic Flow:	2.0 - 2.5 gpm
Cycle Time:	10 - 12 seconds
Bearings:	Self-lubricating Composite Material
Actuator:	Patented Thinline Rack and Pinion Rotary Actuator
Finish:	Safety Yellow Powder Coating

DIMENSIONS ACCOMMODATE THE FOLLOWING UNITS	
PART NO.	DESCRIPTION
1905-0104	EVTL 2212 + 15" DWT (24V ENGLAND)
1905-0107	EVTL 2212 + 15" DWT (DUAL HAND VALVE)
1905-0109	EVTL 2212 + 15" DWT (NO CONTROLS)
1905-0113	EVTL 2212 + 15" DWT (SEQUENCE VALVE)
1905-0204	EVTL 2212 + 15" DWT (24V FULL ELECT.)
1905-0209	EVTL 2212 + 15" DWT (12V FULL ELECT.)

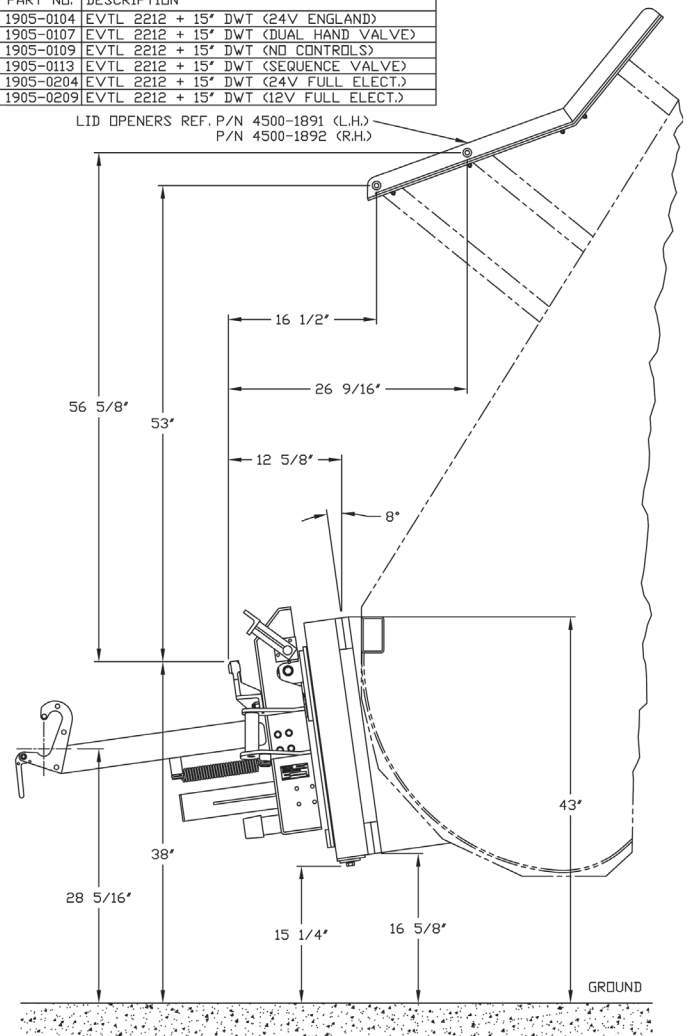

NOTE:
 1. DIMENSIONS ACCOMMODATE MOST ANSI Z245.60-1996 TYPE C (EUROPEAN) CONTAINERS, BUT MAY VARY DUE TO CONTAINER SPECIFICATIONS OR APPLICATIONS.
 2. DIMENSIONS REFER TO EMPTY TRUCK WITH FULLY CHARGED SUSPENSION.

Provides an excellent solution for residential and commercial collection with a single truck!

**Call Our Knowledgeable Sales Staff Today!
 We Offer Fast...Same Day Shipping On Most Of Our In Stock Replacement Refuse Parts**

**Holtz Industries, Inc. • 200 South Terrace Court • Newark, OH 43055
 Call Us Toll Free: 1-800-535-0104 • Local: 740-366-4002 • Fax: 740-366-0771**